

- NOTES:**
- D** VALVE ADJUSTMENT PROCEDURE (TO BE DONE BEFORE ASSEMBLING)
- CONNECT DC POWERSUPPLY TO THE SOLENOID.
 - TO ADJUST, GRADUALLY BACK OUT SEAT FROM THE PORT "P" UNTIL THE SOLENOID ACTIVATES AT 19.5 ± 0.1 VDC.
 - DO NOT LEAVE SOLENOID CONNECTED TO POWERSUPPLY FOR MORE THAN 5 SECONDS AT THE TIME.
 - IF THE SOLENOID IS LEFT CONNECTED TO THE POWERSUPPLY FOR MORE THAN 5 SECONDS, DISCONNECT IT AND LET IT COOL DOWN FOR 15 MINUTES BEFORE CONTINUING ADJUSTMENT.
 - CONNECT DC POWERSUPPLY TO THE SOLENOID.
 - TO ADJUST, GRADUALLY BACK OUT SEAT FROM THE PORT "P" 1.5 TURN OR UNTIL THE SOLENOID ACTIVATES AT 16.5 ± 0.1 VDC, WHICHEVER COMES FIRST.
 - DO NOT LEAVE SOLENOID CONNECTED TO POWERSUPPLY FOR MORE THAN 5 SECONDS AT THE TIME.
 - IF THE SOLENOID IS LEFT CONNECTED TO THE POWERSUPPLY FOR MORE THAN 5 SECONDS, DISCONNECT IT AND LET IT COOL DOWN FOR 15 MINUTES BEFORE CONTINUING ADJUSTMENT.
 - APPLY TEFLON TAPE (ITEM 19) ON THREADS OF ITEMS 1,2,11,12,13,14,16 & 17 BEFORE INSTALLATION.

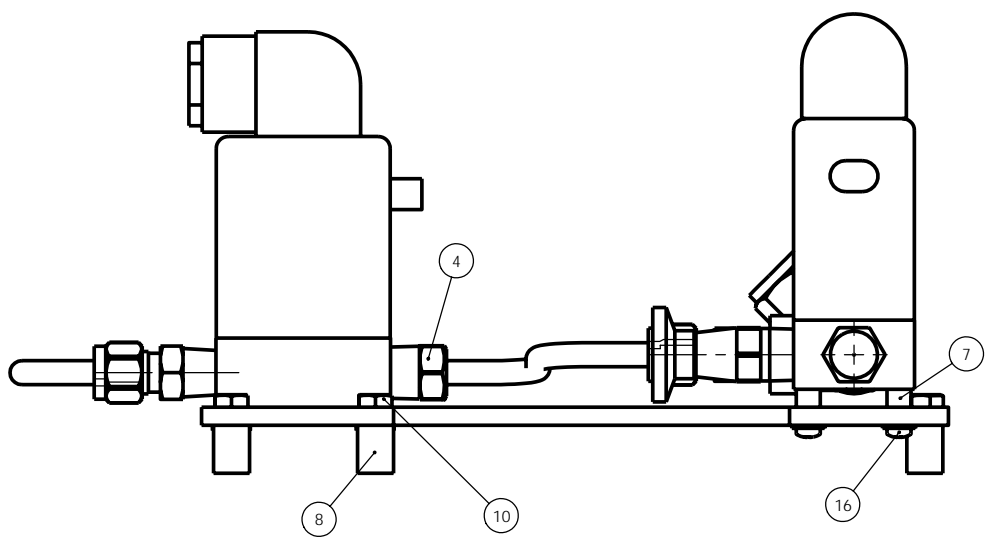

REVISIONS				
SYM	DESCRIPTION	DATE	BY	CHK
A	RELEASE FOR PRODUCTION ECN0797	09/12/02	GR	EM
B	UPDATE REV 213-6255-00 FROM A TO B PER ECN0839	10/22/02	GR	EM
C	UPDATE REV 213-6255-00 FROM B TO C, DELETE M10-0001-05, ADD M10-0001-20 PER ECN0842	11/11/02	GR	EM
D	CHANGE BOM: PART POS.9 FROM M50-0120-42 TO PM0824, PART POS.11 FROM PM0731 TO PM0821, PART POS.12 FROM PM0732 TO PM0822. NOTES REWRITTEN PER ECN0909	01/23/03	GR	EM

POS.	PART NO.	DESCRIPTION	QTY.
1	210-6140-00	PLUG .25NPT .007DIA HOLE	1
2	213-6255-00 rev C	PLATE, VALVES	1
3	213-6274-00 rev A	PIPE, SOL 3WAY-2WAY	1
4	213-6285-00 rev A	PLUG .25NPT .020DIA HOLE	1
5	wash fl M4 218981307		4
6	wash lock M4 218984007		8
7	spac .250ODx.166IDx.187lq ss M10-0001-13		4
8	spac .375ODx.192IDx.500lq al M10-0001-20		4
9	scr pan hd M4x0.7 12.0 12.0 PM0824		4
10	Nut keps #8-32 M50-0130-01		4
11	PM0821 valve 2way stst body	PM0821	1
12	PM0822 valve 3way stst body	PM0822	1
13	elbow .25NPTx.375OD swagelok PM0741		1
14	PM0752tee .25NPTx.25NPTx.25NPT ss		1
15	straight .25NPTx.250OD swagelok PM0754		2
16	scr pan hd M4x0.7 16.0 16.0 PM0756		4
17	PM0759 adaptor 1.2x1.4NPT	ADAPTOR 1/4 NPT	1
18	M70-0004-01 #242 loctite blue		AR
19	M70-0049-01 teflon tape		AR

THIS PRINT IS THE EXCLUSIVE PROPERTY OF SAVANT INSTRUMENTS INC. ANY UNAUTHORIZED REPRODUCTION OR USE THEREOF IS PROHIBITED.		ThermoSavant 100 Colin Drive Holbrook, NY 11741	
UNLESS OTHERWISE SPECIFIED DIMS. ARE IN INCHES. TOLS. ARE: (Ø DEC PL34-01) (Ø DEC PL34-005) ANG. #1/2"		VALVES ASSEMBLY, PUMP	
DO NOT SCALE DWG.	DRN. BY: GR	DATE: 01/23/03	C 213-1045-00 D
BREAK ALL SHARP EDGES.	CHK. BY: EM		
RECH. ENG. EM	ELECT. ENG.		SCALE: FULL
NEXT ASSY DRAWING NO.		SHEET 1 OF 1	